

Technical Data

1100 Series

Gen Set

1104A-44TG2

79,1 kWm @ 1500 rev/min
90,2 kWm @ 1800 rev/min

Basic technical data

Number of cylinders	4
Cylinder arrangement	Vertical in-line
Cycle	Four stroke
Induction system	Turbocharged
Compression ratio	17.25 : 1
Bore	105 mm (4.13 in)
Stroke	127 mm (4.99 in)
Cubic capacity	4.4 litres
Direction of rotation	Clockwise view from front
Firing order	1,3,4,2
Total weight (engine only)	
-dry	463 kg
-wet	485 kg

Overall dimensions

-height	951 mm (37.44 in)
-length	1241 mm (48.85 in)
-width (including mounting brackets)	629 mm (24.76 in)

Moment of inertia (mk²)

Engine:	
- longitudinal	34,5 kgm ²
- horizontal	48,8 kgm ²
- axial	25,1 kgm ²
Flywheel (polar)	1,14 kgm ²

Centre of gravity (wet)

- forward from rear of block	270 mm (10.62 in)
- above centre line of block	151 mm (5.94 in)
- offset of RHS of centre line	13 mm (0.51 in)

Performance

Steady state speed stability at constant load:

G2	± 0.75%
G3	± 0.5%

Note: All data based on operation to ISO 3046/1, BS 5514 and DIN 6271 standard reference conditions.

Test conditions

Air temperature	25 °C
Barometric pressure	100 kPa
Relative humidity	30%

Sound level

Overall sound pressure level (cooling pack and air cleaner fitted):	
- at 1500 rev/min	89,7 dBA
- at 1800 rev/min	92,0 dBA

Sound pressure level from the mean of 4 microphones at the front, left, right and above the engine. Exhaust was piped away out of the test cell.

If the engine is to operate in ambient conditions other than those of the test conditions, suitable adjustments must be made for these changes. For full details, contact Perkins Technical Service Department.

General installation

Designation	Units	Type of Operation and Application			
		Prime	Stand-by	Prime	Stand-by
		50 Hz	50 Hz	60 Hz	60 Hz
Gross engine power	kWm	73,4	80,7	84,5	93,0
Brake mean effective pressure	kPa (lbf/in ²)	1335 (193.6)	1467 (212.7)	1280 (185.6)	1409 (204.3)
Mean piston speed	m/s (ft/s)	6,35 (20.8)	6,35 (20.8)	7,62 (25.0)	7,62 (25.0)
ElectropaK net engine power	kWm	71,9	79,1	82,0	90,2
Engine coolant flow 35 kPa restriction	l/min (UK gal/min)	142 (31.2)	142 (31.2)	170 (37.3)	170 (37.3)
Combustion air flow	m ³ /min (ft ³ /min)	4,8 (169.5)	5,14 (181.5)	6,2 (218.9)	6,5 (229.5)
Exhaust gas flow (max)	m ³ /min (ft ³ /min)	12,5 (441.4)	13,3 (469.6)	15,0 (529.7)	15,85 (559.7)
Exhaust gas temperature (max) in manifold	°C (°F)	555 (1031)	580 (1076)	535 (995)	560 (1040)
Cooling fan air flow	m ³ /min (ft ³ /min)	89,0 (3143.0)	89,0 (3143.0)	111,0 (3919.9)	111,0 (3919.9)
Overall thermal efficiency	%	39,5	39,5	38,5	39,5
Typical genset electrical unit (0.8 pf 25° C)	kWe	64,0	70,4	73,0	80,3
	kVA	80,0	88,0	91,3	100,3
Assumed alternator efficiency	%	89%			
Energy balance					
Power in fuel (Fuel heat of combustion)	kW (Btu/min)	186,0 (10587.0)	204,0 (11611.6)	220,0 (12522.3)	236,0 (13433.0)
Power output (gross)	kW (Btu/min)	73,4 (4177.9)	80,7 (4593.4)	84,5 (4809.7)	93,0 (5293.5)
Power to cooling fan	kW (Btu/min)	1,5 (85.3)	1,6 (91.0)	2,5 (142.2)	2,8 (159.3)
Power output (net)	kW (Btu/min)	71,9 (4092.5)	79,1 (4502.3)	82,0 (4667.4)	90,2 (5134.1)
Power to coolant and lubricating oil	kW (Btu/min)	46,0 (2618.3)	51,0 (2902.9)	53,0 (3016.7)	57,0 (3244.4)
Power to exhaust	kW (Btu/min)	53,0 (3016.7)	59,0 (3358.2)	68,0 (3870.5)	71,0 (4041.2)
Power to radiation	kW (Btu/min)	13,0 (739.9)	14,0 (796.8)	14,0 (796.8)	15,0 (853.7)

Caution: The airflows shown in this table will provide acceptable cooling for an open power unit operating in ambient temperatures of up to 53 °C (127 °F) or 46 °C (114.8 °F) if a canopy is fitted. If the power unit is to be enclosed totally, a cooling test should be done to check that the engine cooling is acceptable. If there is insufficient cooling, contact Perkins Technical Service Department.

Cooling system

Radiator

- face area 0.276 m² (2.97 ft²)
- rows and materials..... double row aluminium
- matrix density and material..... Aluminium 12,5 fins/inch
- width of matrix..... 526 mm (20.7 in)
- height of matrix..... 524 mm (20.6 in)
- pressure cap setting..... 107 kPa

Fan

- diameter..... 457,0 mm (18 in)
- drive ratio..... 1,25 : 1
- number of blades..... 7
- material..... Composite
- type..... Pusher

Coolant

- Total system capacity
- with radiator..... 13,0 l (27.4 pt)
- without radiator..... 7,0 l (14.7 pt)
- Maximum top tank temperature..... 110 °C (230 °F)
- Thermostat operating range..... 82 - 93 °C (180 - 199 °F)
- Recommended coolant: 50 % ethylene glycol with a corrosion inhibitor (BS 658 : 1992 or MOD AL39) and 50% clean fresh water.

Electrical system

- Type..... Negative ground
- Alternator voltage..... 12 V
- Alternator output..... 65 amps
- Starter motor voltage..... 12 V
- Starter motor power..... 3 kW
- Number of teeth on flywheel..... 126
- Pull in current of starter motor solenoid..... 60 amps
- Hold in current of starter motor solenoid..... 15 amps
- Engine stop solenoid..... 12 V
- Stop solenoid (minimum)
- pull in current..... 10 amps
- hold in current..... 10 amps

Cold start recommendations

- Minimum cranking speed..... 105 rev/min

Starter specification

Starter motor type	Minimum starting temperature	Lubricating oil viscosity SAE / battery type - values in CCA			
		15W/40	10W/40	5W/40	5W/30
12 volt 3.0 kW	°C (°F)				
	-10 (14)	1 x 810			
	-15 (5) *		1 x 810		
	-20 (-4) *			1 x 810	
	-25 (-13) *				1 x 900

* - Glow plug start aid fitted.

CCA - Cold Cracking Amps to SAEJ537.

Notes:

- Battery capacity is defined by the 20 hour rate
- If a change to a low viscosity oil is made, the cranking torque necessary at lower ambient temperatures is much reduced. The starting equipment has been selected to take advantage of this. It is important to change the appropriate multigrade oil in anticipation of operating in low ambient temperatures.
- Breakaway current is dependent on battery capacity available. Cables should be capable of handling the transient current which may be up to double the steady cranking current.

Exhaust system

- Maximum back pressure
- 1500 rev/min..... 10 kPa
- 1800 rev/min..... 15 kPa
- Exhaust outlet size..... 64 mm (2.5 in)

Fuel System

- Type of injection..... Direct
- Fuel injection pump..... Rotary
- Fuel atomiser..... Multi-hole
- Nozzel opening pressure..... 29,0 MPa (290 bar)

Fuel lift pump

- Type..... Electrical
- flow/hour..... 120 - 150 l/h (211 - 264 pt/m)
- pressure..... 30 - 75 kPa (4.4 - 10.9 psi)
- Maximum suction head..... 17 kPa (2.46 psi)

Governor type

- Electronic governor (optional)..... Woodward LCG2
- Electronic governor speed control to..... ISO 8528 , G3 (Hot)
- Mechanical governor speed control to..... ISO 8528, G2 (Cold)

Fuel specification

Fuel Specification	European RF75-T-96 / DIN EN590 / BS2869 class A2
Density (kg/l @ 15 °C)	0,835 - 0,845
Viscosity (mm ² /s @ 40 °C)	2,5 - 3,5
Sulphur content (%)	0,1 - 0,2
Cetane number	45 - 50

Fuel consumption litres/hour (UK gals/hr)

Speed	Power rating				
	110%	100%	75%	50%	25%
1500	20,5 (4.5)	18,7 (4.1)	14,0 (3.0)	9,7 (2.1)	5,2 (1.1)
1800	24,4 (5.3)	22,3 (4.9)	16,9 (3.7)	11,9 (2.6)	6,5 (1.4)

Induction system

Maximum air intake restriction

- clean filter..... 5,0 kPa
- dirty filter..... 8,0 kPa
- air filter type..... Dry

Lubrication system

Lubricating oil capacity

- Total system..... 8,0 l (16.9 pt)
- Sump minimum..... 5,5 l (11.6 pt)
- Sump maximum..... 7,0 l (14.7 pt)

Maximum engine operating angles:

- front up, front down, right side or left side..... 25°

Lubricating oil pressure

- relief valve opens..... 415 - 470 kPa
- at maximum no-load speed..... 276 - 414 kPa
- Max continuous oil temperature..... 125 °C (257 °F)
- Oil consumption at full load as a % of fuel consumption..... 0.15%

1104A-44TG2 Electropak - left view

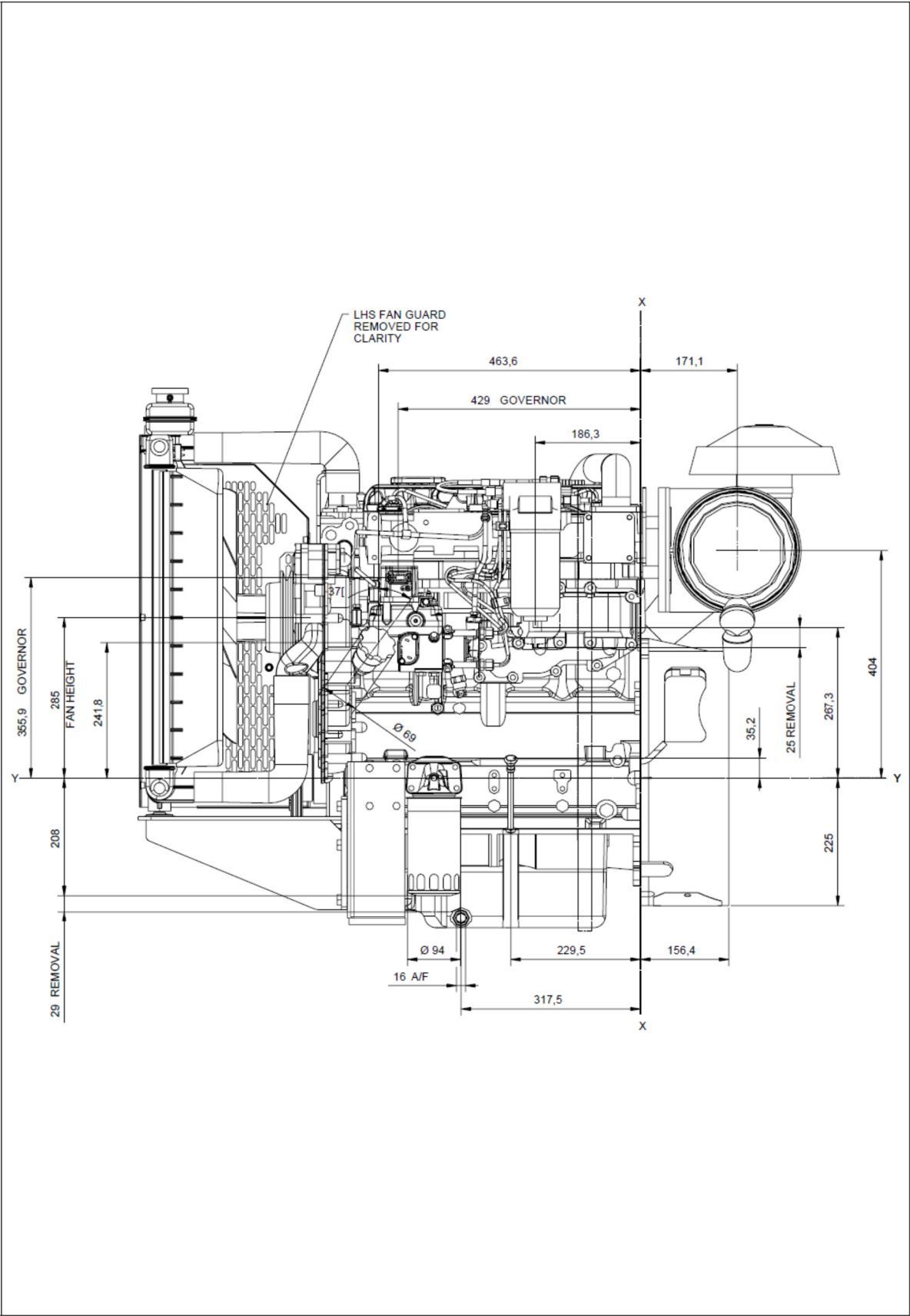

1104A-44TG2 Electropak - front view

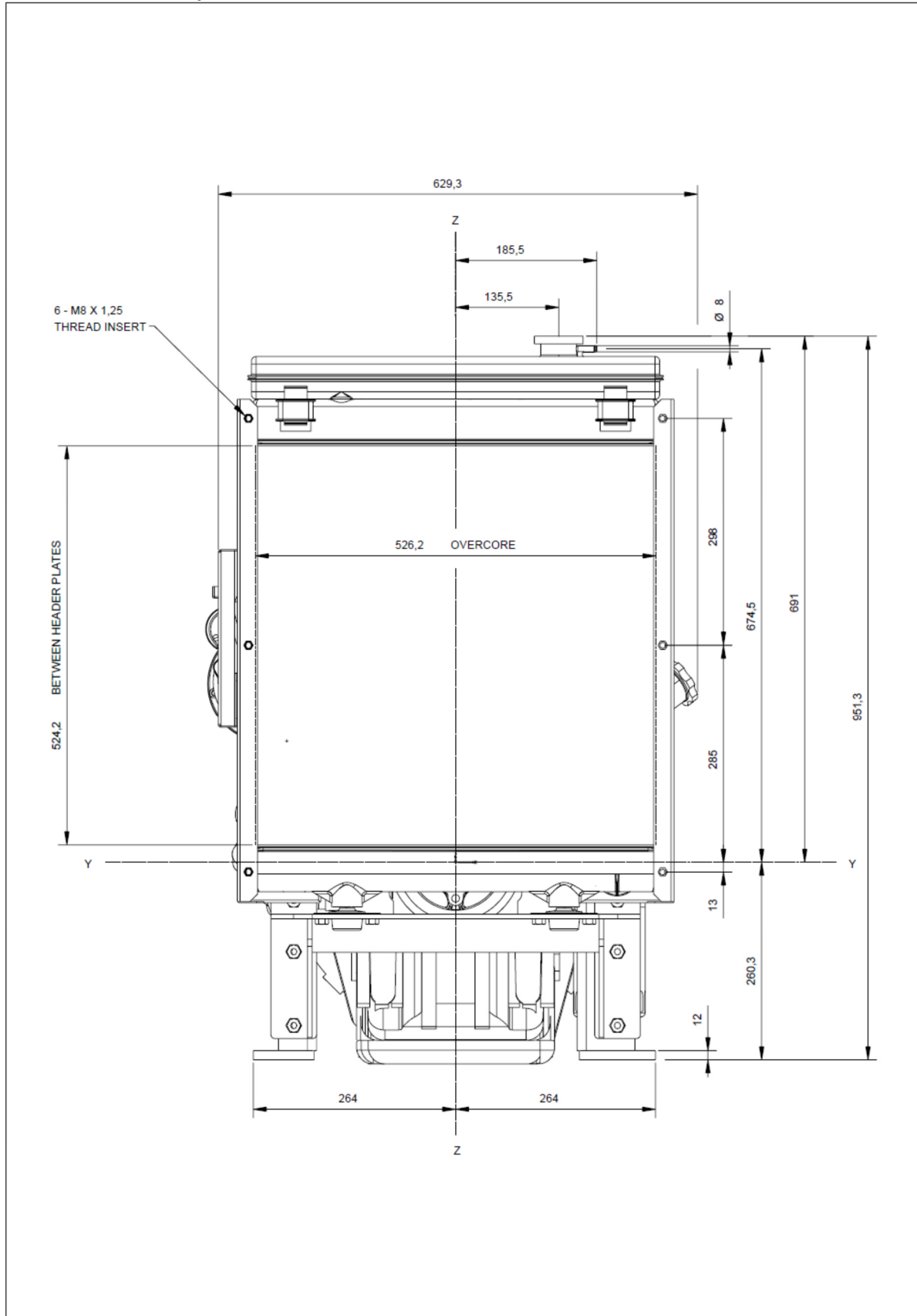

1104A-44TG2 ElectropaK - right view

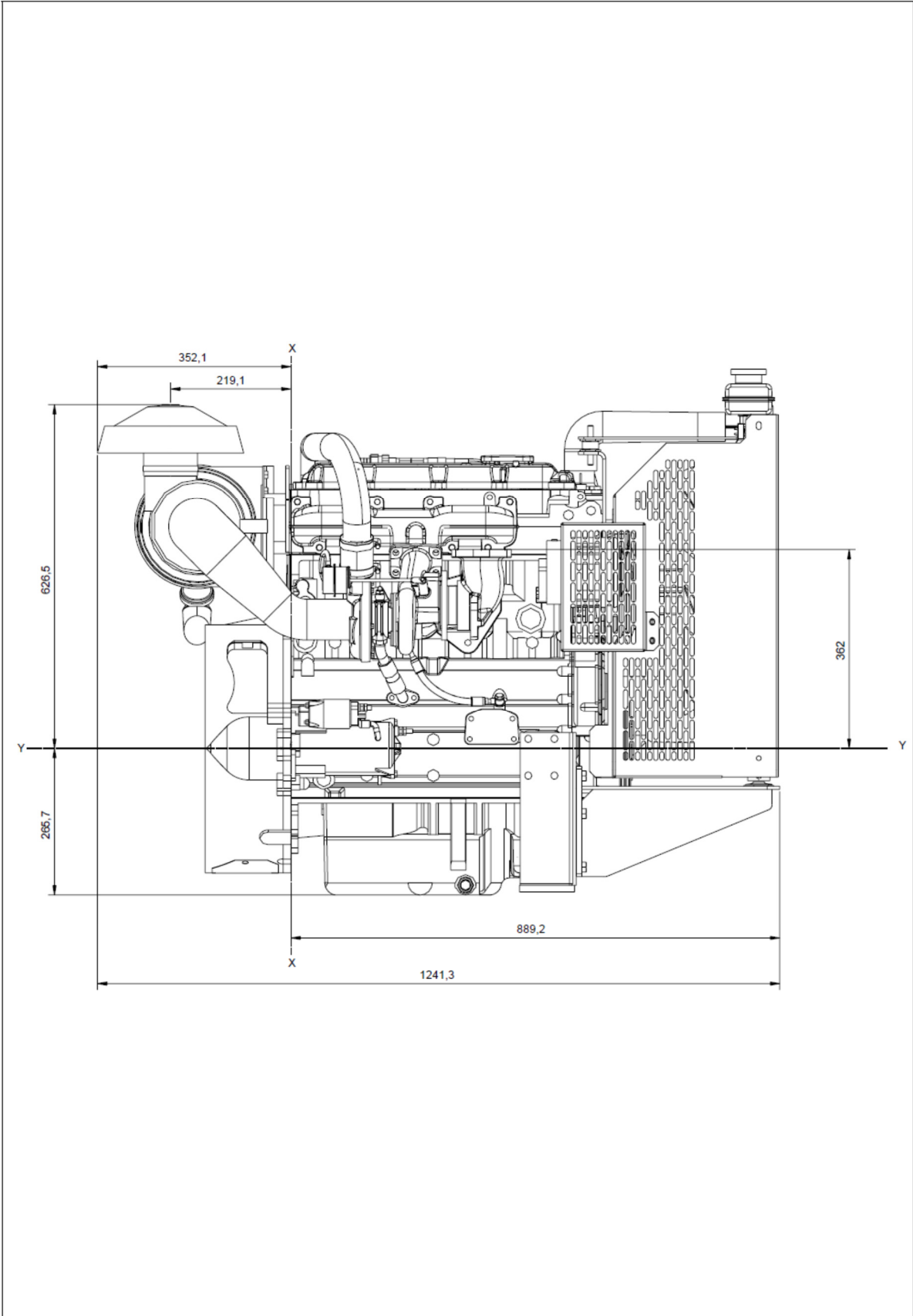

1104A-44TG2 ElectropaK - rear view

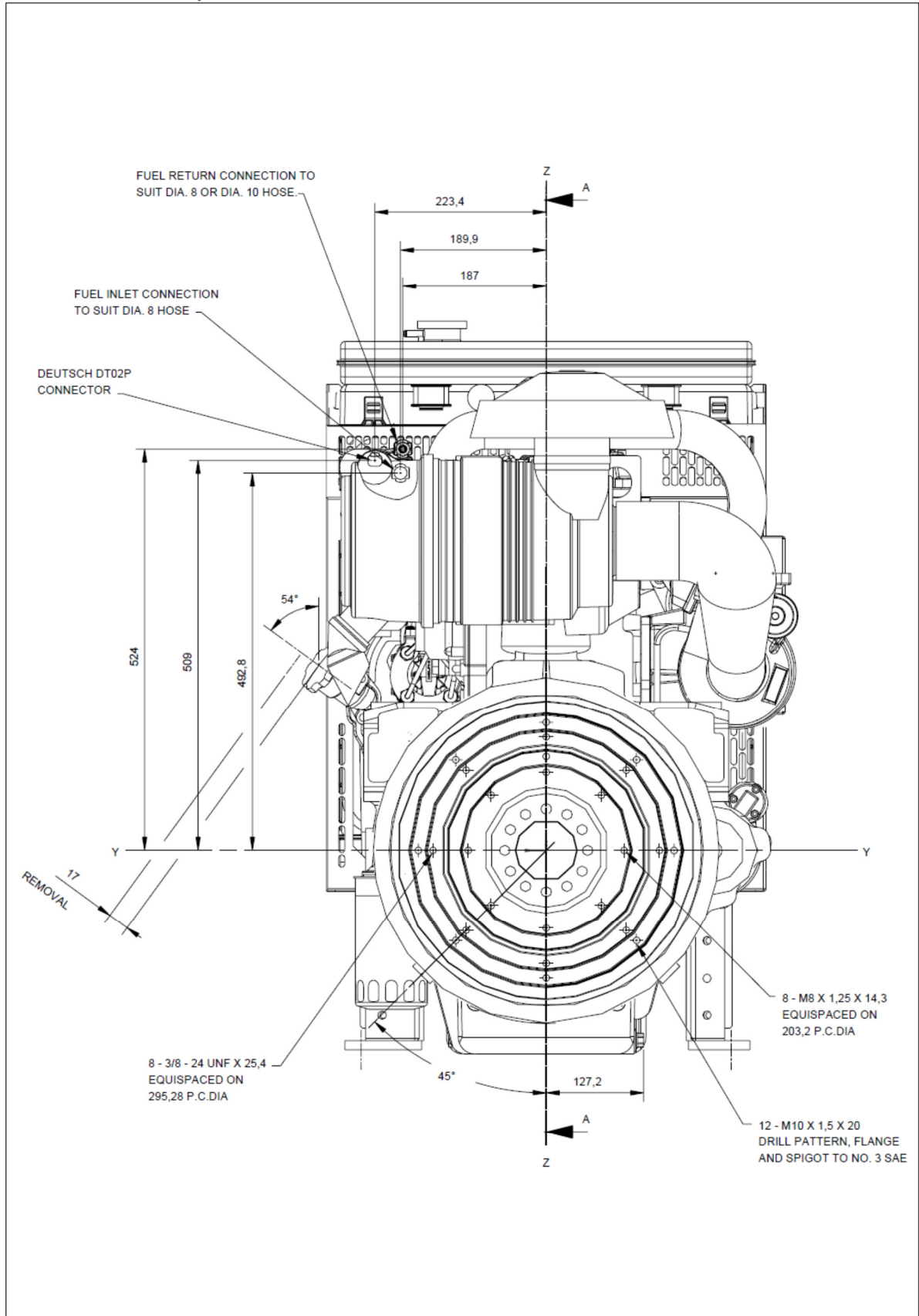

Recommended SAE viscosity

A single or multigrade oil must be used which conforms to API-CG4 / CH4, see illustration below:

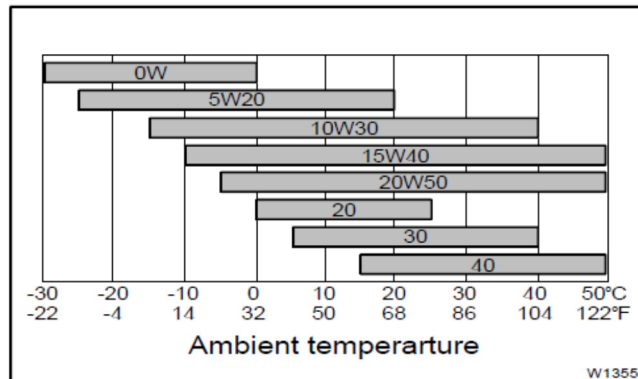

Mountings

Maximum static bending moment
at rear face of block ... 791 Nm (583 lb/ft)

Load Acceptance

Initial load application when engine reaches rated speed (15 seconds max after engine starts to crank)			
	Units	1500 rev/ min	1800 rev/ min
Prime Power	%	90	100
Load	kW (kWe)	66,1 (57.5)	84,2 (72.4)
Transient frequency deviation	%	<-10%	<-10%
Frequency recovery	seconds	< 1	< 1

The above complies with requirements of classification 3 & 4 of ISO 8528-12 and G2 operating limits stated in ISO 8528-5. The above figures were obtained under the test conditions as follows:

Engine block temperature ... 45 °C
 Alternator ... 96%
 Maximum ambient temperature ... 10%

Isochronous governing:

- typical alternator inertia ... 50 kgm²

All tests were conducted using an engine which was installed and serviced to Perkins Engines Company Limited recommendations.

The information given in this document is for guidance only.